



FEATURES

- This relay has an **Mini-ISO (International Organization for Standardization) terminal arrangement.**
- **Relay is compact and high capacity (40 A).**
Compact form factor realized with space saving 22 × 26 mm .866 × 1.024 inch small base area thanks to integrated bobbin and base construction. Features high switching capacity of 40 A
- **Features high thermal resistance of 125°C 257°F (heat resistant type).**
Heat resistant type is available that can withstand use near engines. (40 A switching capacity)
- **Built-in resistor type is also available.**

TYPICAL APPLICATIONS

- **Automobiles**
Headlights, Cell motors, Air conditioners, ABS, EPS, etc.
- **Construction equipment**
- **Agricultural equipment, Conveyor, etc.**

ORDERING INFORMATION

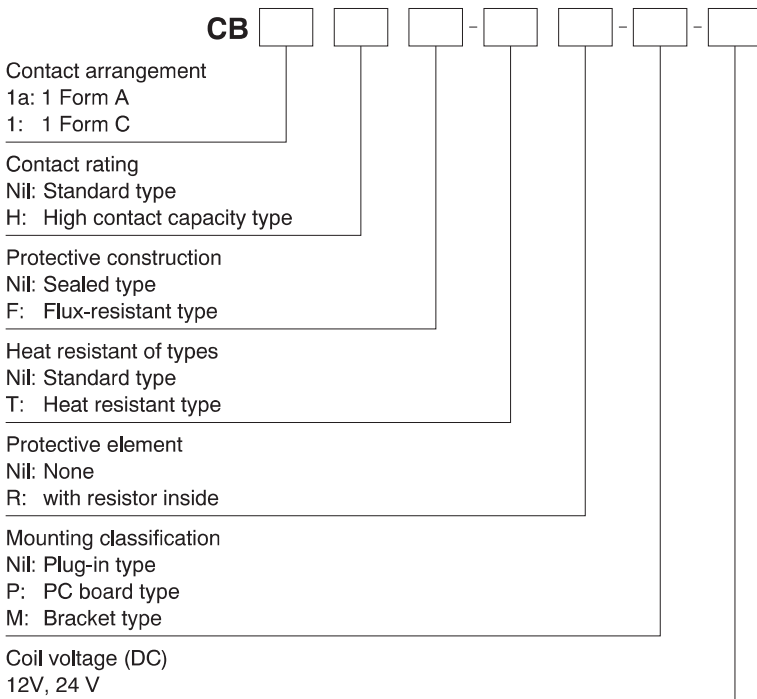

TYPES

1. Standard type

| Contact arrangement | Mounting classification | Nominal coil voltage | Sealed type | Flux-resistant type |
|-------------------------------------|-------------------------|----------------------|-------------|---------------------|
| | | | Part No. | Part No. |
| 1 Form A | PC board type | 12V DC | CB1a-P-12V | CB1aF-P-12V |
| | | 24V DC | CB1a-P-24V | CB1aF-P-24V |
| | Plug-in type | 12V DC | CB1a-12V | CB1aF-12V |
| | | 24V DC | CB1a-24V | CB1aF-24V |
| | Bracket type | 12V DC | CB1a-M-12V | CB1aF-M-12V |
| | | 24V DC | CB1a-M-24V | CB1aF-M-24V |
| 1 Form C | PC board type | 12V DC | CB1-P-12V | CB1F-P-12V |
| | | 24V DC | CB1-P-24V | CB1F-P-24V |
| | Plug-in type | 12V DC | CB1-12V | CB1F-12V |
| | | 24V DC | CB1-24V | CB1F-24V |
| | Bracket type | 12V DC | CB1-M-12V | CB1F-M-12V |
| | | 24V DC | CB1-M-24V | CB1F-M-24V |
| High contact capacity (1 Form A) | PC board type* | 12V DC | CB1aH-P-12V | CB1aHF-P-12V |
| | | 24V DC | CB1aH-P-24V | CB1aHF-P-24V |
| | Plug-in type | 12V DC | CB1aH-12V | CB1aHF-12V |
| | | 24V DC | CB1aH-24V | CB1aHF-24V |
| | Bracket type | 12V DC | CB1aH-M-12V | CB1aHF-M-12V |
| | | 24V DC | CB1aH-M-24V | CB1aHF-M-24V |

Standard packing; Carton: 50 pcs. Case: 200 pcs.

Note: Please use "CB***R**" to order with resistor inside type. (Asterisks "*" should be filled in from ORDERING INFORMATION.)

2. Heat resistant type

| Contact arrangement | Mounting classification | Nominal coil voltage | Sealed type | Flux-resistant type |
|-------------------------------------|-------------------------|----------------------|---------------|---------------------|
| | | | Part No. | Part No. |
| 1 Form A | PC board type | 12V DC | CB1a-T-P-12V | CB1aF-T-P-12V |
| | | 24V DC | CB1a-T-P-24V | CB1aF-T-P-24V |
| | Plug-in type | 12V DC | CB1a-T-12V | CB1aF-T-12V |
| | | 24V DC | CB1a-T-24V | CB1aF-T-24V |
| | Bracket type | 12V DC | CB1a-T-M-12V | CB1aF-T-M-12V |
| | | 24V DC | CB1a-T-M-24V | CB1aF-T-M-24V |
| 1 Form C | PC board type | 12V DC | CB1-T-P-12V | CB1F-T-P-12V |
| | | 24V DC | CB1-T-P-24V | CB1F-T-P-24V |
| | Plug-in type | 12V DC | CB1-T-12V | CB1F-T-12V |
| | | 24V DC | CB1-T-24V | CB1F-T-24V |
| | Bracket type | 12V DC | CB1-T-M-12V | CB1F-T-M-12V |
| | | 24V DC | CB1-T-M-24V | CB1F-T-M-24V |
| High contact capacity (1 Form A) | PC board type* | 12V DC | CB1aH-T-P-12V | CB1aHF-T-P-12V |
| | | 24V DC | CB1aH-T-P-24V | CB1aHF-T-P-24V |
| | Plug-in type | 12V DC | CB1aH-T-12V | CB1aHF-T-12V |
| | | 24V DC | CB1aH-T-24V | CB1aHF-T-24V |
| | Bracket type | 12V DC | CB1aH-T-M-12V | CB1aHF-T-M-12V |
| | | 24V DC | CB1aH-T-M-24V | CB1aHF-T-M-24V |

Standard packing; Carton: 50 pcs. Case: 200 pcs.

Note: Please use "CB***R**" to order with resistor inside type. (Asterisks "*" should be filled in from ORDERING INFORMATION.)

RATING

1. Coil data

1) No protective element

| Contact arrangement | Nominal coil voltage | Pick-up voltage | Drop-out voltage | Nominal operating current | Coil resistance | Nominal operating power | Usable voltage range |
|-------------------------------------|----------------------|-----------------|------------------|---------------------------|-----------------|-------------------------|----------------------|
| 1 Form A, 1 Form C | 12V DC | 3 to 7V DC | 1.2 to 4.2V DC | 117mA | 103Ω | 1.4W | 10 to 16V DC |
| | 24V DC | 6 to 14V DC | 2.4 to 8.4V DC | 75mA | 320Ω | 1.8W | 20 to 32V DC |
| High contact capacity (1 Form A) | 12V DC | 3 to 7V DC | 1.2 to 4.2V DC | 117mA | 103Ω | 1.4W (PC board type) | 10 to 16V DC |
| | | | | 150mA | 80Ω | 1.8W | |
| | 24V DC | 6 to 14V DC | 2.4 to 8.4V DC | 58mA | 411Ω | 1.4W (PC board type) | 20 to 32V DC |
| | | | | 75mA | 320Ω | 1.8W | |

Note: Other pick-up voltage types are also available. Please contact us for details.

2) With resistor inside

| Contact arrangement | Nominal coil voltage | Pick-up voltage (Initial, at 20°C 68°F) | Drop-out voltage (Initial, at 20°C 68°F) | Nominal operating current (at 20°C 68°F) | Combined resistance (±10%) (at 20°C 68°F) | Nominal operating power (at 20°C 68°F) | Usable voltage range |
|-----------------------|----------------------|--|---|---|---|---|----------------------|
| 1 Form A, 1 Form C | 12V DC | 3 to 7V DC | 1.2 to 4.2V DC | 134mA | 89.5Ω | 1.6W | 10 to 16V DC |
| | 24V DC | 6 to 14V DC | 2.4 to 8.4V DC | 84mA | 287.2Ω | 2.0W | 20 to 32V DC |

2. Specifications

1) Standard type (12 V coil voltage)

| Characteristics | Item | Specification | | |
|----------------------------|--|---|---|--|
| Contact | Arrangement | 1 Form A | 1 Form C | High contact capacity (1 Form A) |
| | Contact resistance (Initial) | Typ2mΩ (By voltage drop 6 V DC 1 A) | | |
| | Contact material | Ag alloy (Cadmium free) | | |
| Rating | Nominal switching capacity (Initial) | 40A 14V DC | N.O.: 40A 14V DC N.C.: 30A 14V DC | 70A 14V DC (at 20°C 68°F) 50A 14V DC (at 85°C 185°F) |
| | Max. carrying current (Initial) (14V DC, at 85°C 185°F, continuous) | N.O.: 40A | N.O.: 40A, N.C.: 30A | N.O.: 40A |
| | Nominal operating power | 1.4W | 1.4W | 1.8W (1.4W: PC board type) |
| | Min. switching capacity (resistive load)*1 | 1A 14V DC | | |
| Electrical characteristics | Insulation resistance (Initial) | Min. 20 MΩ (at 500V DC, Measurement at same location as "Breakdown voltage" section.) | | |
| | Breakdown voltage (Initial) | Between open contacts | 500 Vrms for 1 min. (Detection current: 10mA) | |
| | | Between contacts and coil | 500 Vrms for 1 min. (Detection current: 10mA) | |
| | Operate time (at nominal coil voltage) (at 20°C 68°F) | Max. 15ms (excluding contact bounce time) (Initial) | | |
| | Release time (at nominal coil voltage) (at 20°C 68°F) | Max. 15ms (excluding contact bounce time) (Initial) | | |
| Mechanical characteristics | Shock resistance | Functional | Min. 200 m/s ² {20G} | |
| | | Destructive | Min. 1,000 m/s ² {100G} | |
| | Vibration resistance | Functional | 10 Hz to 500 Hz, Min. 44.1m/s ² {4.5G} | |
| | | Destructive | 10 Hz to 2,000 Hz, Min. 44.1m/s ² {4.5G} | Time of vibration for each direction; X. Y. Z direction: 4 hours |
| Expected life | Electrical (at nominal switching capacity) | Flux-resistant type: Min. 10 ⁶ , Sealed type: Min. 5×10 ⁴ (Operating frequency: 2s ON, 2s OFF) | | |
| | Mechanical | Min. 10 ⁶ (at 120 cpm) | | |
| Conditions | Conditions for operation, transport and storage*2 | Standard type; Ambient temperature: -40 to +85°C -40 to +185°F, Humidity: 5 to 85% R.H. (Not freezing and condensing at low temperature) | | |
| | | Heat resistant type; Ambient temperature: -40 to +125°C -40 to +257°F, Humidity: 5 to 85% R.H. (Not freezing and condensing at low temperature) | | |
| | Max. operating speed | 15 cpm (at nominal switching capacity) | | |
| Mass | | Approx. 33 g 1.16 oz | | |

Notes:

*1. This value can change due to the switching frequency, environmental conditions, and desired reliability level, therefore it is recommended to check this with the actual load.

*2. The upper operation ambient temperature limit is the maximum temperature that can satisfy the coil temperature rise value. Refer to "6. Usage, Storage and Transport Conditions" in [AMBIENT ENVIRONMENT section in Relay Technical Information](#).

2) Standard type (24 V coil voltage)

| Characteristics | Item | Specifications | | |
|-----------------|--|--|--------------------------------------|----------------------------------|
| Contact | Arrangement | 1 Form A | 1 Form C | High contact capacity (1 Form A) |
| | Contact resistance (Initial) | Max. 15mΩ (By voltage drop 6 V DC 1 A) | | |
| | Contact material | Ag alloy (Cadmium free) | | |
| Rating | Nominal switching capacity (Initial) | 20A 28V DC | N.O.: 20A 28V DC N.C.: 10A 28V DC | 20A 28V DC |
| | Max. carrying current (Initial) (28V DC, at 85°C 185°F, continuous) | 20A | N.O.: 20A, N.C.: 10A | 20A |
| | Nominal operating power | 1.8W | 1.8W | 1.8W, 1.4W (PC board type) |

Note: All other specifications are the same as those of standard type (12 V coil voltage)

3) Heat resistant type (12 V and 24 V coil voltage)

| Characteristics | Item | Specifications | | | | | |
|-----------------|---|--|--------------------------------------|----------------------------------|------------|--------------------------------------|----------------------------------|
| | | 12V | | | 24V | | |
| Contact | Arrangement | 1 Form A | 1 Form C | High contact capacity (1 Form A) | 1 Form A | 1 Form C | High contact capacity (1 Form A) |
| | Contact resistance (Initial) | Max. 15mΩ (By voltage drop 6 V DC 1 A) | | | | | |
| | Contact material | Ag alloy (Cadmium free) | | | | | |
| Rating | Nominal switching capacity (Initial) | 40A 14V DC | N.O.: 40A 14V DC N.C.: 30A 14V DC | 40A 14V DC | 20A 28V DC | N.O.: 20A 28V DC N.C.: 10A 28V DC | 20A 28V DC |
| | Max. carrying current (Initial) (at 85°C 185°F, continuous)* | 50A 14V DC | N.O.: 50A 14V DC N.C.: 30A 14V DC | 45A 14V DC 50A 14V DC | 25A 28V DC | N.O.: 25A 28V DC N.C.: 10A 28V DC | 25A 28V DC |
| | Nominal operating power | 1.4W | 1.4W | 1.8W 1.4W (PC board type) | 1.8W | 1.8W | 1.8W, 1.4W (PC board type) |

Notes: 1. All other specifications are the same as those of standard type (12 V coil voltage)

2. *Current value in which carry current is possible when the coil temperature is 180°C 356°F

REFERENCE DATA

CB RELAYS (Standard type)

1. Allowable ambient temperature
(Heat resistant standard type)

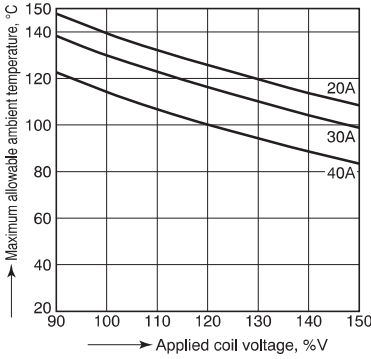

Assumption:
 • Maximum mean coil temperature: 180°C
 • Curves are based on 1.4W (Nominal power consumption of the unsuppressed coil at nominal voltage)

2. Max. switching capability (Resistive load)
(Standard type)

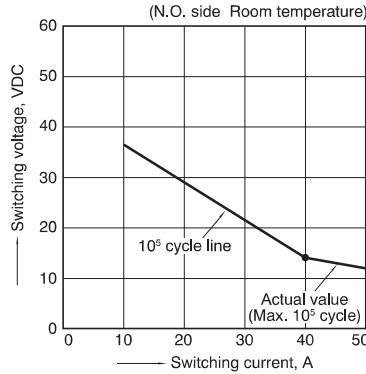

3. Ambient temperature and operating voltage range
(Standard type)

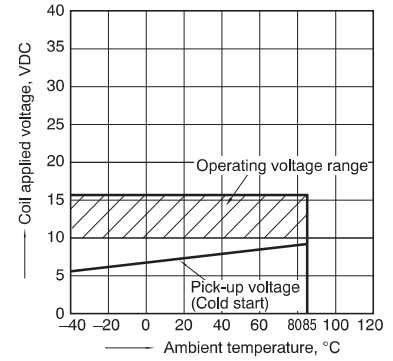

4. Distribution of pick-up and drop-out voltage
Sample: CB1-P-12V, 42pcs.

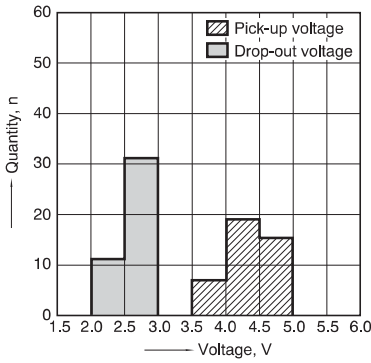

5. Distribution of operate and release time
Sample: CB1-P-12V, 42pcs.

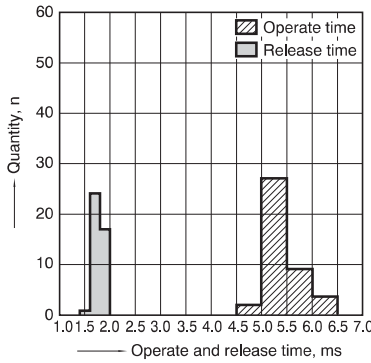

6. Electrical life test (Motor free)

Sample: CB1F-12V, 5pcs.
 Load: 25A 14V DC, motor free actual load
 Operating frequency: ON 1s, OFF 9s
 Ambient temperature: Room temperature
 Circuit

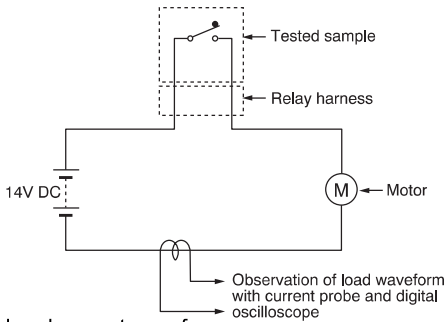

Load current waveform
 Inrush current: 80A, Steady current: 25A

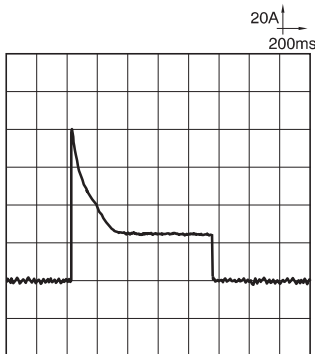

Change of pick-up and drop-out voltage

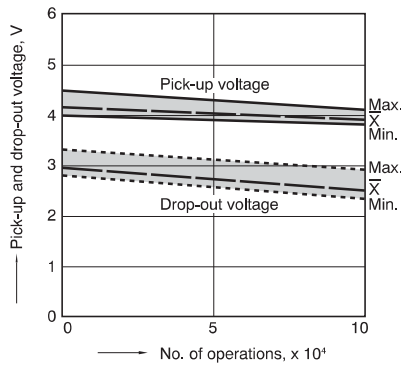

Change of contact resistance

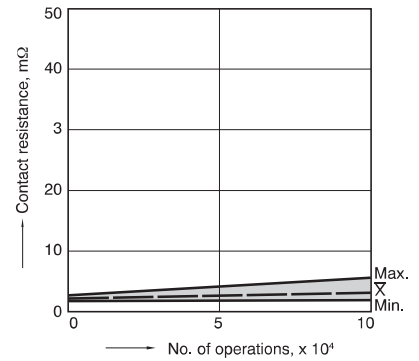

CB RELAYS (High contact capacity type)

1. Allowable ambient temperature
(High resistant/high contact capacity type)

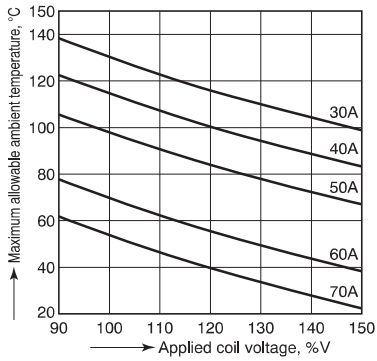

Assumption:

- Maximum mean coil temperature: 180°C
- Curves are based on 1.4W (Nominal power consumption of the unsuppressed coil at nominal voltage)

2. Ambient temperature and operating voltage range
(High contact capacity/standard type)

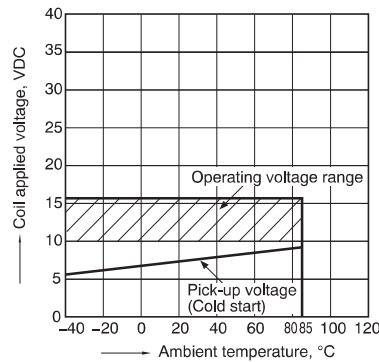

3. Distribution of pick-up and drop-out voltage
Sample: CB1aHF-12V, 53pcs.

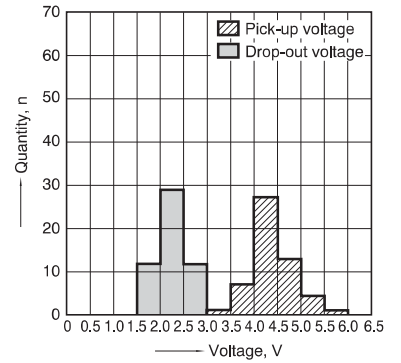

4. Distribution of operate and release time
Sample: CB1aHF-12V, 53pcs.

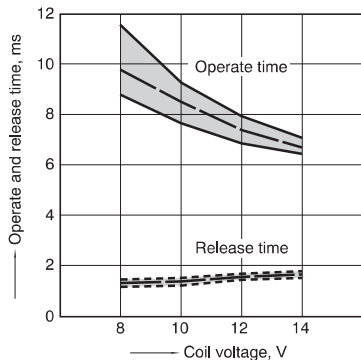

5. Contact resistance
Sample: CB1aHF-12V, 53pcs.
(By voltage drop 6V DC 1A)

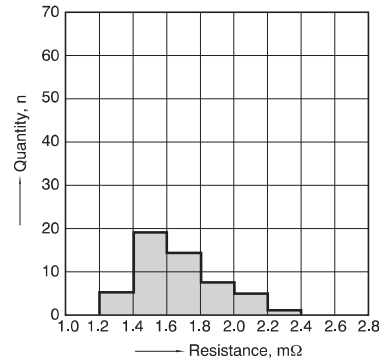

6. Electrical life test (Motor free)

Sample: CB1aH-12V, 3pcs.
Load: Inrush current: 64A/Steady current: 35A
Fan motor actual load (motor free) 12V DC
Operating frequency: ON 3s, OFF 7s
Ambient temperature: Room temperature
Circuit

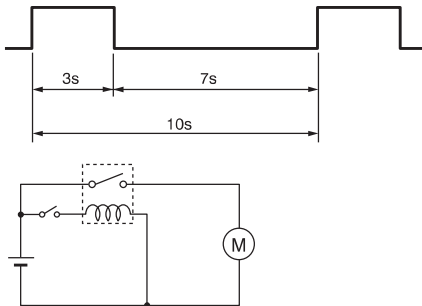

Load current waveform

Inrush current: 64A, Steady current: 35A

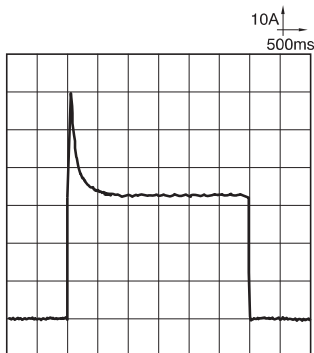

Change of pick-up and drop-out voltage

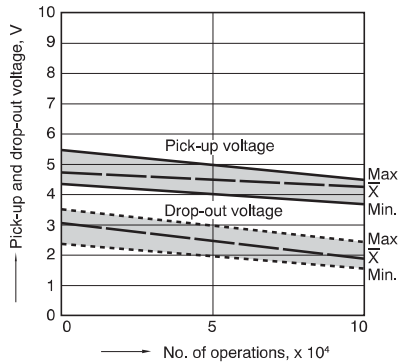

Change of contact resistance

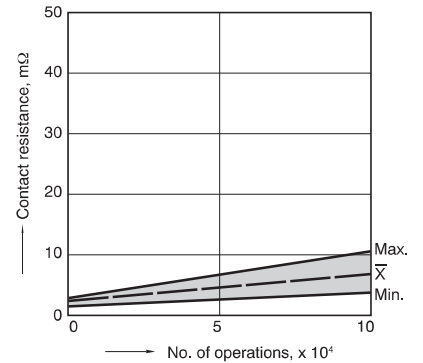

DIMENSIONS (mm inch)

Download [CAD Data](#) from our Web site.

1. PC board type

[CAD Data](#)



External dimensions

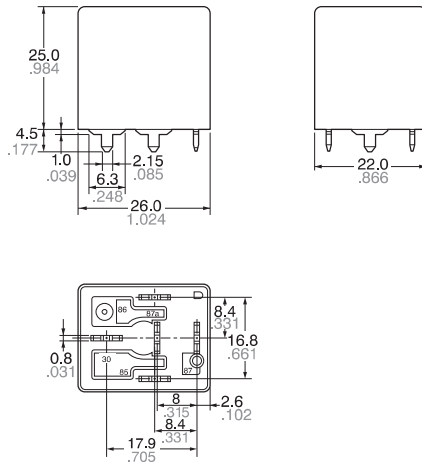

Dimension:
 Max. 1mm .039 inch:
 1 to 3mm .039 to .118 inch:
 Min. 3mm .118 inch:

General tolerance
 ±0.1 ±.004
 ±0.2 ±.008
 ±0.3 ±.012

Schematic (Bottom view)

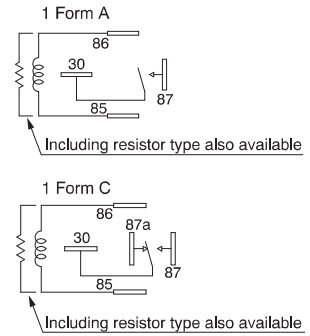

PC board pattern (Bottom view)

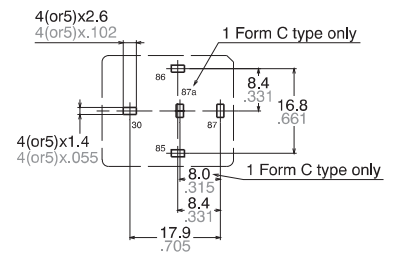

Tolerance: ±0.1 ±.004

2. Plug-in type

[CAD Data](#)



External dimensions

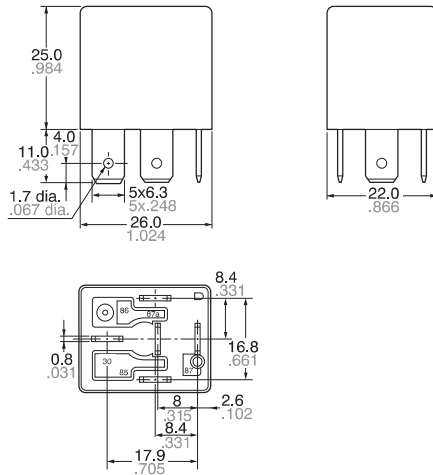

Dimension:
 Max. 1mm .039 inch:
 1 to 3mm .039 to .118 inch:
 Min. 3mm .118 inch:

General tolerance
 ±0.1 ±.004
 ±0.2 ±.008
 ±0.3 ±.012

Schematic (Bottom view)

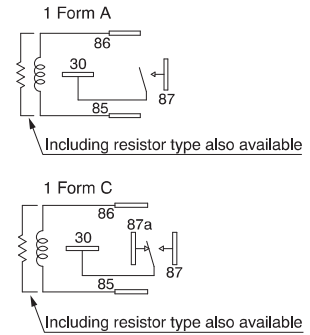

3. Bracket type

[CAD Data](#)



External dimensions

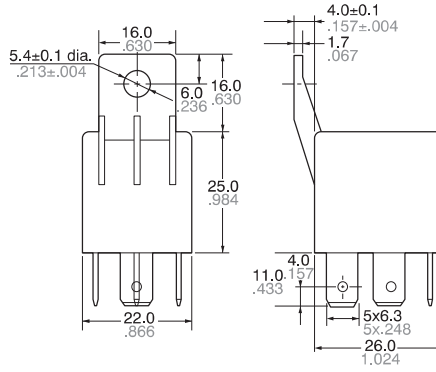

Schematic (Bottom view)

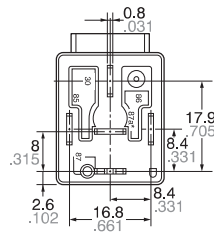
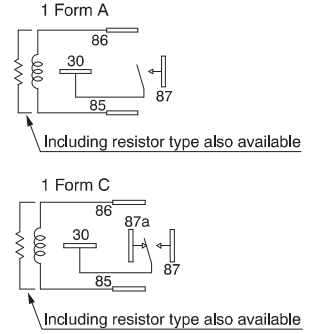

| <u>Dimension:</u> | <u>General tolerance</u> |
|-----------------------------|--------------------------|
| Max. 1mm .039 inch: | ±0.1 ±.004 |
| 1 to 3mm .039 to .118 inch: | ±0.2 ±.008 |
| Min. 3mm .118 inch: | ±0.3 ±.012 |

4. High contact capacity type (1 Form A) (Plug-in type)

[CAD Data](#)



External dimensions

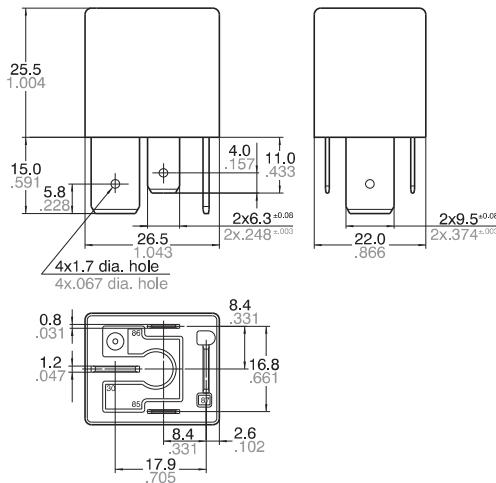

Schematic (Bottom view)

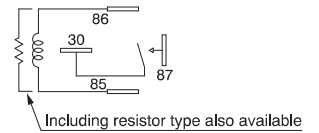

| <u>Dimension:</u> | <u>General tolerance</u> |
|-----------------------------|--------------------------|
| Max. 1mm .039 inch: | ±0.1 ±.004 |
| 1 to 3mm .039 to .118 inch: | ±0.2 ±.008 |
| Min. 3mm .118 inch: | ±0.3 ±.012 |

5. High contact capacity type (1 Form A) (PC board type)

CAD Data



External dimensions

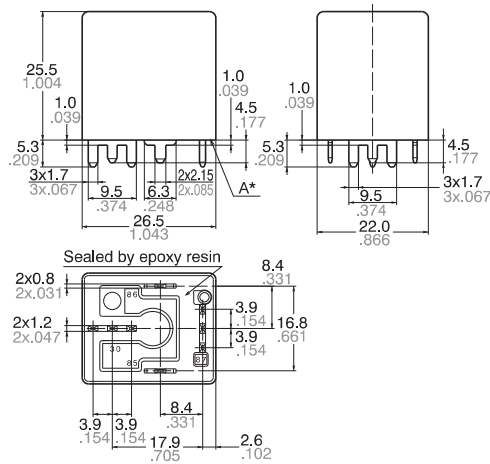

Schematic (Bottom view)

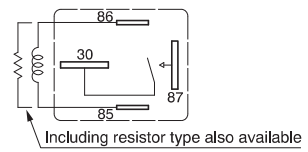

PC board pattern (Bottom view)

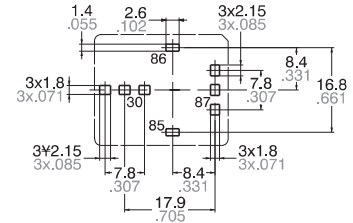

Tolerance: $\pm 0.1 \pm .004$

* Intervals between terminals is measured at A surface level.

| Dimension: | General tolerance |
|-----------------------------|--------------------|
| Max. 1mm .039 inch: | $\pm 0.1 \pm .004$ |
| 1 to 3mm .039 to .118 inch: | $\pm 0.2 \pm .008$ |
| Min. 3mm .118 inch: | $\pm 0.3 \pm .012$ |

NOTES

1. Soldering

Max. 350°C 662°F (solder temperature), within 3 seconds (soldering time)
 The effect on the relay depends on the actual PC board used. Please verify the PC board to be used.

2. Usage, transport and storage conditions

- 1) Ambient temperature, humidity, and atmospheric pressure during usage, transport, and storage of the relay:
 - (1) Temperature: -40 to $+85^{\circ}\text{C}$ -40 to $+185^{\circ}\text{F}$ (Standard type)
 - -40 to $+125^{\circ}\text{C}$ -40 to $+257^{\circ}\text{F}$ (High heat-resistant type)
 - (2) Humidity: 2 to 85% RH (Avoid freezing and condensation.)
 - (3) Atmospheric pressure: 86 to 106 kPa
 The humidity range varies with the temperature. Use within the range indicated in the graph below.
 (Temperature and humidity range for usage, transport, and storage)

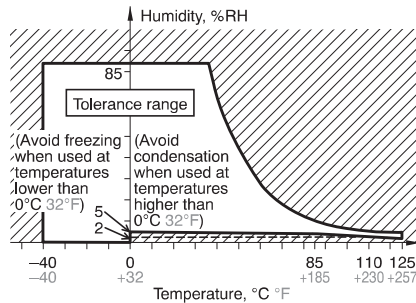

For Cautions for Use, see [Relay Technical Information](#).